

1. STAND-OFFS:
 6 THRU 18 POSN (2) REQD LOCATED AS SHOWN OUTBOARD OF END CIRCUITS.
 20 THRU 38 POSN (3) REQD LOCATED OUTBOARD OF END CIRCUITS PLUS (1) CENTERED.
 40 THRU 74 POSN (4) REQD LOCATED OUTBOARD OF END CIRCUITS WITH (2) EVENLY SPACED WITHIN THE REMAINING LENGTH.
- △ 2 ACCESS SLOT
 △ 3 .000100-.000200 BRIGHT TIN-LEAD OVER .000050 NICKEL.
 △ 4 .000100-.000200 BRIGHT TIN OVER .000050 NICKEL.
 △ 5 PRELIMINARY PART
 △ 6 .000100-.000200 MATTE TIN OVER .000050 NICKEL

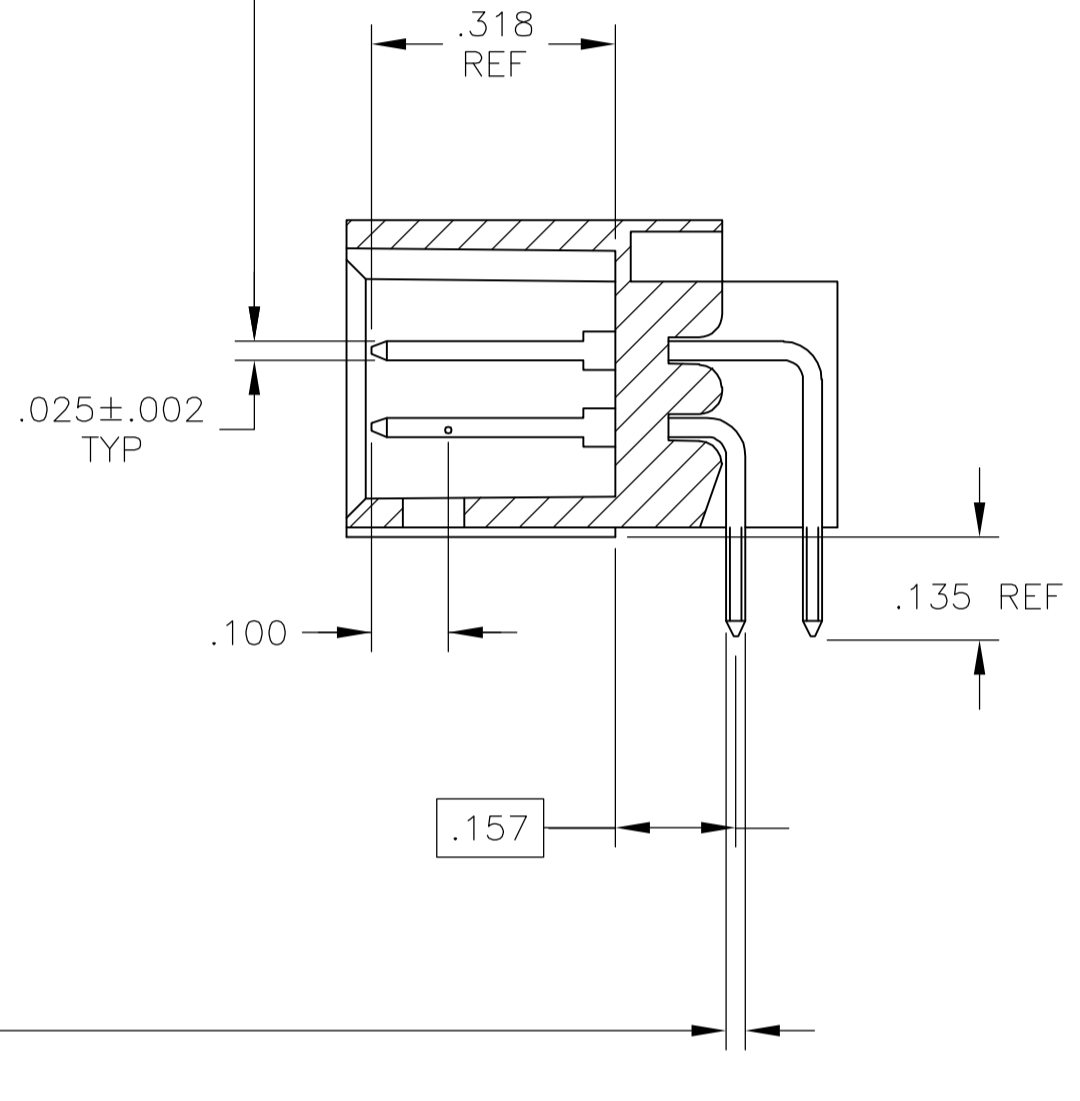

SECTION X-X

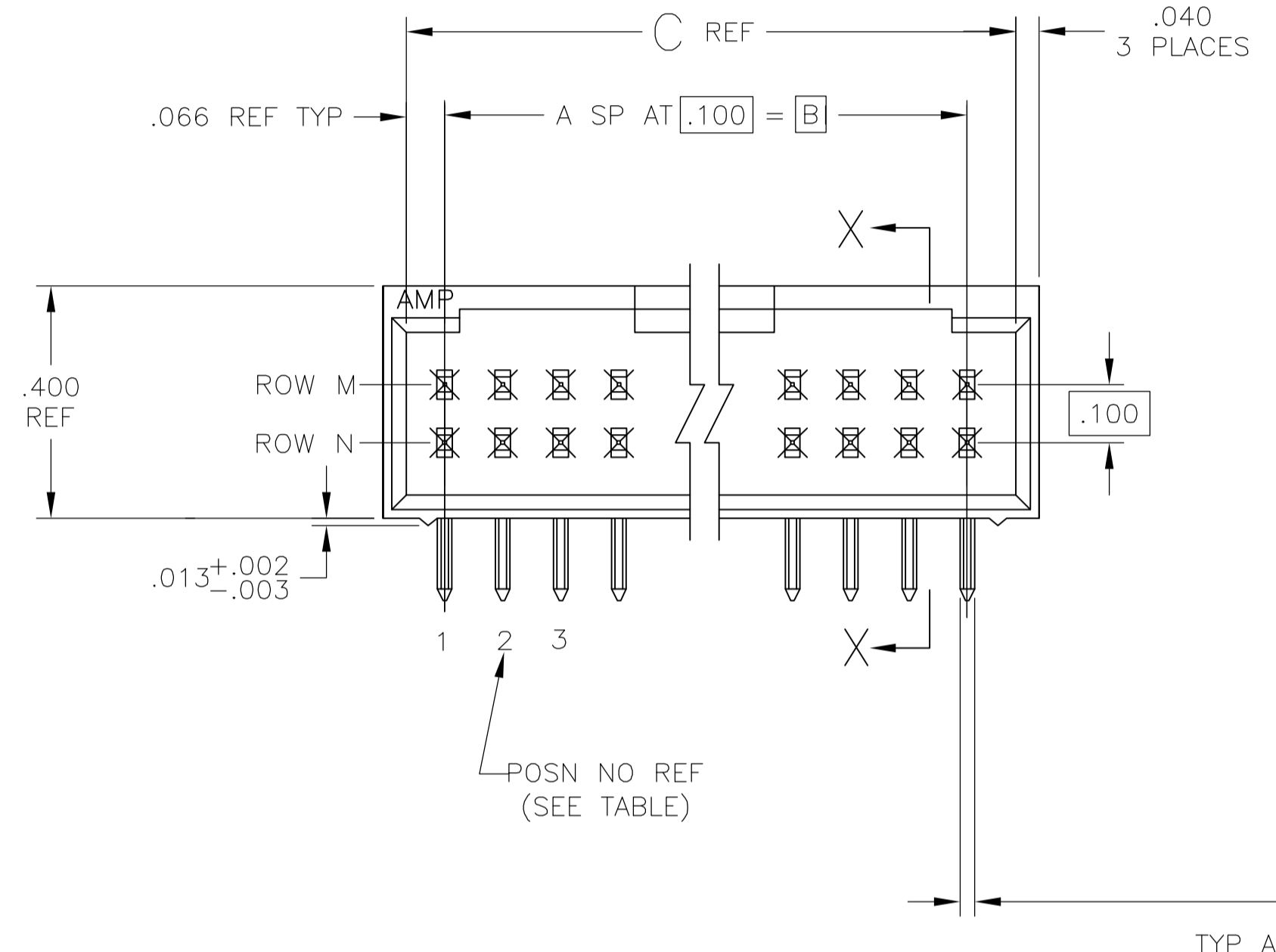
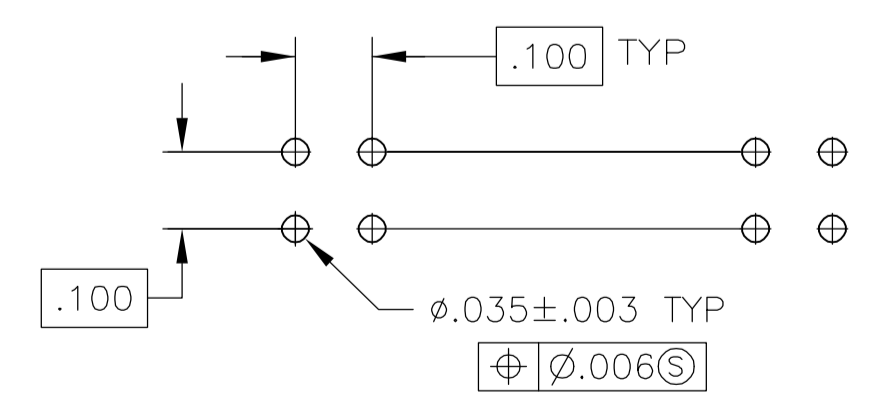
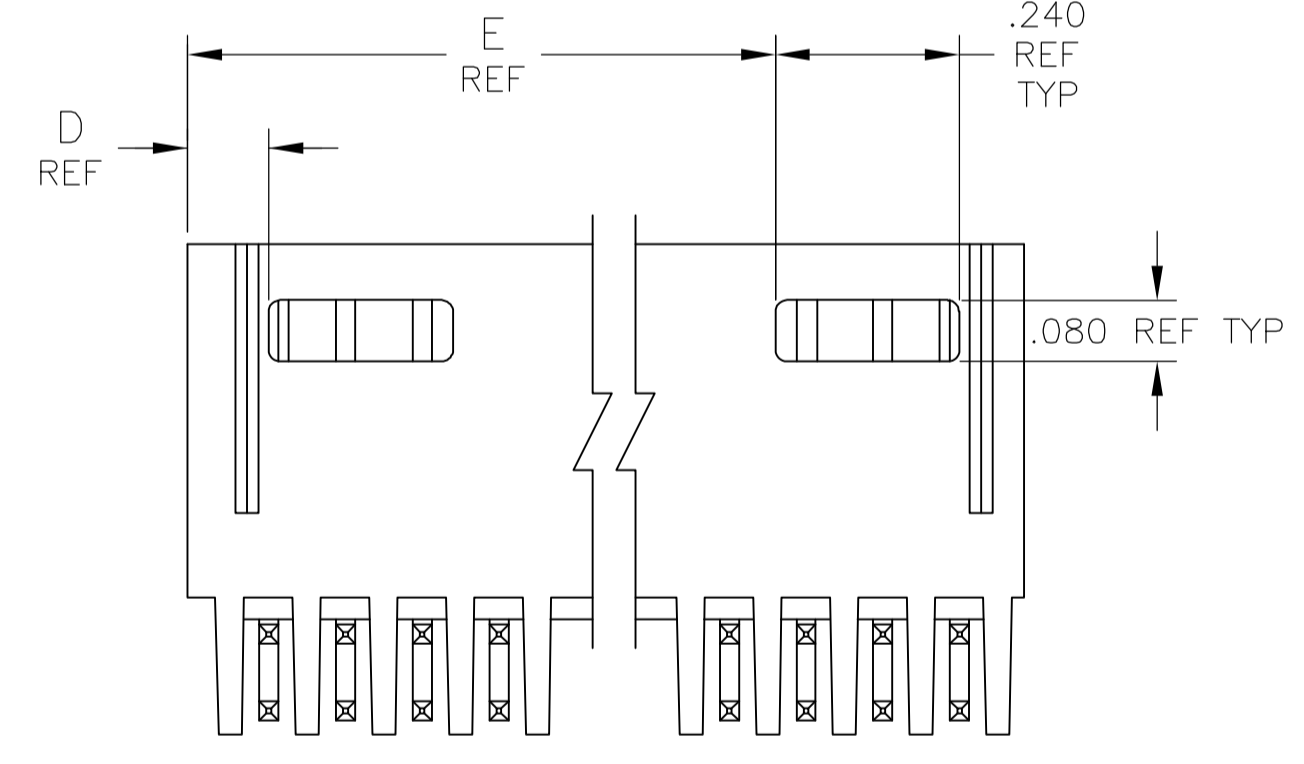

RECOMMENDED HOLE LAYOUT

FINISH	E	D	C	B	A	NO. OF POSN	PART NO.
△ 6	-	.106	.332	.200	2	6	8-87579-5
△ 6	3.506	.106	3.732	3.600	36	74	8-87579-4
△ 6	3.406	.106	3.632	3.500	35	72	8-87579-3
△ 6	3.306	.106	3.532	3.400	34	70	8-87579-2
△ 6	3.206	.106	3.432	3.300	33	68	8-87579-1
△ 6	3.106	.106	3.332	3.200	32	66	8-87579-0
△ 6	3.006	.106	3.232	3.100	31	64	7-87579-9
△ 6	2.906	.106	3.132	3.000	30	62	7-87579-8
△ 6	2.806	.106	3.032	2.900	29	60	7-87579-7
△ 6	2.706	.106	2.932	2.800	28	58	7-87579-6
△ 6	2.606	.106	2.832	2.700	27	56	7-87579-5
△ 6	2.506	.106	2.732	2.600	26	54	7-87579-4
△ 6	2.406	.106	2.632	2.500	25	52	7-87579-3
△ 6	2.306	.106	2.532	2.400	24	50	7-87579-2
△ 6	2.206	.106	2.432	2.300	23	48	7-87579-1
△ 6	2.106	.106	2.332	2.200	22	46	7-87579-0
△ 6	2.006	.106	2.232	2.100	21	44	6-87579-9
△ 6	1.906	.106	2.132	2.000	20	42	6-87579-8
△ 6	1.806	.106	2.032	1.900	19	40	6-87579-7
△ 6	1.706	.106	1.932	1.800	18	38	6-87579-6
△ 6	1.606	.106	1.832	1.700	17	36	6-87579-5
△ 6	1.506	.106	1.732	1.600	16	34	6-87579-4
△ 6	1.406	.106	1.632	1.500	15	32	6-87579-3
△ 6	1.306	.106	1.532	1.400	14	30	6-87579-2
△ 6	1.206	.106	1.432	1.300	13	28	6-87579-1
△ 6	1.106	.106	1.332	1.200	12	26	6-87579-0
△ 6	1.006	.106	1.232	1.100	11	24	5-87579-9
△ 6	.906	.106	1.132	1.000	10	22	5-87579-8
△ 6	.806	.106	1.032	.900	9	20	5-87579-7
△ 6	-	.406	.932	.800	8	18	5-87579-6
△ 6	-	.306	.832	.700	7	16	5-87579-5
△ 6	-	.306	.732	.600	6	14	5-87579-4
△ 6	-	.206	.632	.500	5	12	5-87579-3
△ 6	-	.206	.532	.400	4	10	5-87579-2
△ 6	-	.106	.432	.300	3	8	5-87579-1
△ 5	2.806	.106	3.032	2.900	29	60	3-87579-9
△ 4	1.206	.106	1.432	1.300	13	28	3-87579-8
△ 4	-	.306	.832	.700	7	16	3-87579-7
△ 4	-	.208	.632	.500	5	12	3-87579-6
△ 3	-	.106	.332	.200	2	6	3-87579-5
△ 3	3.506	.106	3.732	3.600	36	74	3-87579-4
△ 3	3.406	.106	3.632	3.500	35	72	3-87579-3
△ 3	3.306	.106	3.532	3.400	34	70	3-87579-2
△ 3	3.206	.106	3.432	3.300	33	68	3-87579-1
△ 3	3.106	.106	3.332	3.200	32	66	3-87579-0
△ 3	3.006	.106	3.232	3.100	31	64	2-87579-9
△ 3	2.906	.106	3.132	3.000	30	62	2-87579-8
△ 3	2.806	.106	3.032	2.900	29	60	2-87579-7
△ 3	2.706	.106	2.932	2.800	28	58	2-87579-6
△ 3	2.606	.106	2.832	2.700	27	56	2-87579-5
△ 3	2.506	.106	2.732	2.600	26	54	2-87579-4
△ 3	2.406	.106	2.632	2.500	25	52	2-87579-3
△ 3	2.306	.106	2.532	2.400	24	50	2-87579-2
△ 3	2.206	.106	2.432	2.300	23	48	2-87579-1
△ 3	2.106	.106	2.332	2.200	22	46	2-87579-0
△ 3	2.006	.106	2.232	2.100	21	44	1-87579-9
△ 3	1.906	.106	2.132	2.000	20	42	1-87579-8
△ 3	1.806	.106	2.032	1.900	19	40	1-87579-7
△ 3	1.706	.106	1.932	1.800	18	38	1-87579-6
△ 3	1.606	.106	1.832	1.700	17	36	1-87579-5
△ 3	1.506	.106	1.732	1.600	16	34	1-87579-4
△ 3	1.406	.106	1.632	1.500	15	32	1-87579-3
△ 3	1.306	.106	1.532	1.400	14	30	1-87579-2
△ 3	1.206	.106	1.432	1.300	13	28	1-87579-1
△ 3	1.106	.106	1.332	1.200	12	26	1-87579-0
△ 3	1.006	.106	1.232	1.100	11	24	87579-9
△ 3	.906	.106	1.132	1.000	10	22	87579-8
△ 3	.806	.106	1.032	.900	9	20	87579-7
△ 3	-	.406	.932	.800	8	18	87579-6
△ 3	-	.306	.832	.700	7	16	87579-5
△ 3	-	.306	.732	.600	6	14	87579-4
△ 3	-	.206	.632	.500	5	12	87579-3
△ 3	-	.206	.532	.400	4	10	87579-2
△ 3	-	.106	.432	.300	3	8	87579-1

THIS DRAWING IS A CONTROLLED DOCUMENT. DWN S.A. SHUEY 11-10-89
 GJK R. ELICKER 25-10-89
 APVD R. ELICKER 25-10-89

tyco Electronics Tyco Electronics Corporation
 's-Hertogenbosch, 5222AR-32

HDR ASSY, MOD II, SHROUDED,
 4 SIDES, DBL ROW, .100 X.100 C/L
 RIGHT ANGLE, W/.025 SQ POSTS

SIZE: A1 CAGE CODE: 00779 DRAWING NO: 87579
 WEIGHT: - RESTRICTED TO: -
 CUSTOMER DRAWING SCALE: 4:1 SHEET: 1 OF 1 REV: R